

Olson Marketing Monthly

August 2018 - Issue #84

in partnership with Insane Oil of Omaha

Your Amsoil Information News Source

Product Highlight: Amsoil Severe Gear (NEW "BOTTLE")

The new [SEVERE GEAR](#) easy-pack makes the job of changing differential fluid faster and cleaner, and eliminates the need for a pump. This latest AMSOIL innovation provides an all-in-one solution to challenging gear lube installations.

[AMSOIL SEVERE GEAR 75W-90 and 75W-140 100% Synthetic Gear Lube](#) are now offered in a durable, all-in-one package that makes installation as easy as opening it, inserting the nozzle into the fill hole and squeezing.

Dealer Contact

Lincoln - Olson Marketing

Don & Peg Olson
ZO Referral# 4901
402-489-3930

<http://om.shopamsoil.com>
lubedealerdon@gmail.com

Omaha - Insane Oil

Dr. Jonathan D. & Stacey L. Olson
ZO Referral# 10458
402-990-7940 (text or call)

<http://insaneoil.com>
info@insaneoil.com

What's inside?

More New Products From Amsoil	p. 2
The Altrum Minute - Vitamin D3	p. 3
Diesel Digest - Internal Balancers	p. 4
Shop Talk & Dealer Zone	p. 5



Congratulations:

New Preferred Customers

Richard Buscher
Centreville, VA

Paul Sosa
Houston, TX

Perry Davidson
Anjou, QC

Jay Maxey
Farmington, MN

Michael Neukirch
Lincoln, NE

James Schaepe
Omaha, NE

Michael Young
Pierre, SD

New Catalog Customers

Alan Kondracki
Hillsboro, MO



More New Products From Amsoil

Mudslinger

[Mudslinger® \(AMS\)](#) provides a protective, non-stick layer of armor against the accumulation of mud, dirt and snow on ATVs, UTVs and dirt bikes. It makes removing mud and dirt with low-pressure water easy while protecting against UV rays and keeping equipment looking pristine.



New Toyota/Lexus Filter Cap Wrench

Designed to install and remove [AMSOIL Ea® Oil Filters](#) in hard-to-reach locations, this easy-to-use [64-mm filter wrench \(GA248\)](#) has a combination 3/8" square drive and hex drive for easy installation and removal. Designed with extra thick wall construction to help withstand the higher torques required for the Toyota and Lexus oil filters. Recommended for use with the following filters: Ea15K01, Ea15K02, Ea15K04 and Ea15K49.



Engine Degreaser

[Engine Degreaser \(AED\)](#) is a professional-strength formula packed with powerful degreasing solvents that quickly and easily remove the toughest grease, dirt and grime from engine surfaces. Just spray it on and wash off with water.

Glass Cleaner

[Glass Cleaner \(AGC\)](#) provides a professional-strength formula that effectively cuts through grease and grime faster than other leading glass cleaners. Its foaming action doesn't run or drip, and leaves no streaks or haze.



The Altrum Minute

Research conducted through the past decade suggests that vitamin D deficiency plays a role in increased risk of a host of chronic diseases, such as osteoporosis, heart disease, some cancers, and multiple sclerosis and infectious diseases, such as tuberculosis and the seasonal flu.

There's scientific debate about how much vitamin D people need each day. A report released in 2010 by the Institute of Medicine recommended tripling the daily vitamin D intake for children and adults in the U.S. and Canada, to 600 IU per day.

The report also recognized the safety of vitamin D by increasing the upper limit from 2,000 to 4,000 IU per day, and acknowledged that even at 4,000 IU per day, there was no good evidence of harm, according to The Nutrition Source.

According to experts, the guidelines are overly conservative about the recommended intake, and they do not give enough weight to some of the latest science on vitamin D and health. For bone health and chronic disease prevention, many people are likely to need more vitamin D than these government guidelines recommend.

Vitamin D helps the body absorb and retain calcium and phosphorus, both critical for building bone. Laboratory studies show that vitamin D can reduce cancer cell growth and plays a critical role in controlling infections,

according to Nutrition Source. Many of the body's organs and tissues have receptors for vitamin D, and scientists are still looking for its other possible functions.

Several studies link low vitamin D levels with an increased risk of fractures in older adults, and they suggest that vitamin D supplementation may prevent such fractures — as long as it is taken in a high enough dose.

According to the Nutrition Source article, ongoing research shows initial benefits of vitamin D supplementation in helping to mitigate chronic conditions, some cancers, heart disease and immune function.

Learn more at:

AltrumOnline.com

ALTRUM Vitamin D3 provides 2,000 IU of vitamin D3 and a blend of organic fruits and superfoods. All ingredients are non-GMO.

D3 provides the body, from protecting the health of bones and teeth, to supporting the body's overall immunity, helping to protect against chronic health problems, supporting the nervous system and more.

[ALTRUM Vitamin D3](#) is enriched with a blend of organic fruits and superfoods that also have been shown to provide a multitude of health benefits.

Vitamin D3 provides 2,000 IU of vitamin D3 per capsule. Enriched with organic fruits and superfoods. Fat soluble. Helps maintain healthy bones and teeth. * Helps the body absorb calcium. Supports immune health, nervous-system and cellular function. *

Suggested use: As a dietary supplement, take one or two capsules per day with food.

Keep out of the reach of children.

Contains no genetically modified ingredients (Non-GMO), artificial colors, artificial flavors or preservatives.

*These statements have not been evaluated by the Food and Drug Administration. This product is not intended to diagnose, treat, cure or prevent disease.

Supplement Facts		
Serving Size: 1 Capsule Servings Per Container: 60		
	Amount Per Serving	% Daily Value**
Vitamin D3 (cholecalciferol)	2000 IU	500%
Organic SuperFruit Blend	400 mg	**
Organic amla fruit, organic acai fruit, organic cranberry fruit, organic raspberry fruit		
Organic Greens Blend	300 mg	**
Organic spirulina, organic chlorella		

*** Daily Values are based on 2,000 calorie diet.
** Daily Value not established.

Other Ingredients: Organic pullulan capsule, organic tapioca maltodextrin
Distributed by ALTRUM Nutrition Div. of AMSOIL, INC.
Superior, WI 54980 (715) 350-7101

Net Wt.

Product Code
889-01



Diesel Digest - Internal Balancer

An internal engine balancer is actually an extra shaft that is geared to the crankshaft. It turns in the opposite direction of the crankshaft rotation at a speed that is the same or directly proportional to the crankshaft's rotational speed. The counterweights on the internal balancer create a frequency of vibration that is the exact opposite of the vibrations occurring in the crankshaft. The vibrations produced by the balancer and the crankshaft cancel each other out. Internal balancers are also used to eliminate camshaft vibration.

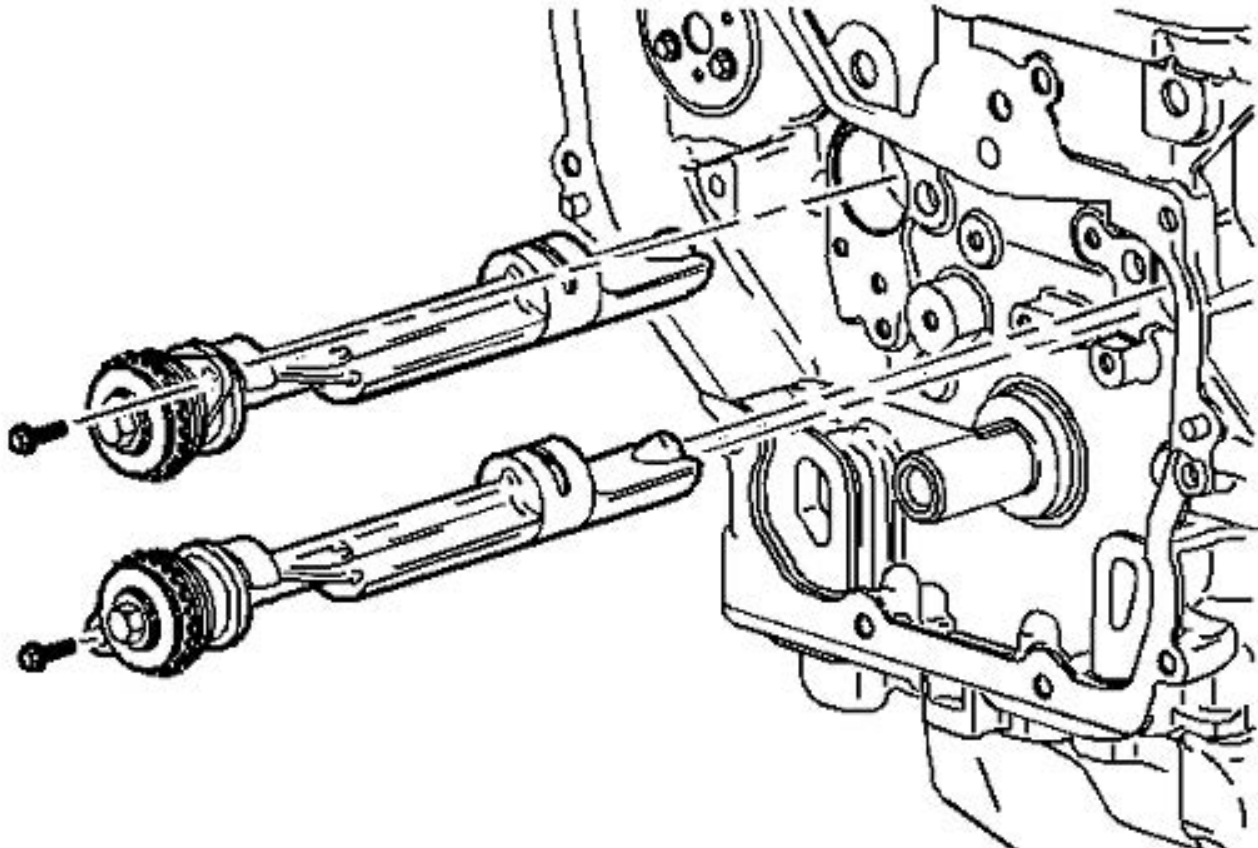

Shop Talk...

with Dr. Jonathan D. Olson, EdD
ZO #10458

I had an opportunity to attend the 45th Anniversary Amsoil Convention this past month. This is the second year that I have attended and each time I have walked away with invaluable tools for the future.

Attending the various sessions allowed me to pinpoint specific components that I will be focusing on and implementing over the next year with regards to my business. Last year I had the same experience and implemented various changes throughout the year for which I could then quantify the results of through Amsoil's analytics and reports.

I also had an opportunity to tour the distribution and research facility in Superior, WI. I am amazed at the facility and enjoyed talking with the engineers and warehouse specialists.



Dealer's Zone

By Don Olson
ZO #4901

Coming this fall (September 2018) I will be having Education Nights at my home for Dealers, PCs, Retail Accounts, and Commercial Accounts. Others can attend as space permits. More information will be forthcoming.

The purpose of the meetings is to let you know about:

- (1) what is happening in the lubrication industry
- (2) New products from AM-SOIL
- (3) Question and answer period
- (4) Occasional guest speakers
- (5) Food supplementation – ALTRUM
- (6) Other interesting and important information.

I may have a couple of meetings before the September time frame to get a feel for interest. Your interest will determine what will be covered at each meeting. Your input is important!

Please submit your subjects to me for inclusion in the series. I will send an E-mail invitation to all interested persons as well as a listing of the next subjects to be covered each meeting. I have limited space, so please let me know which meeting you will be attending. (up to 25 people in cooler weather-up to 8 in hot weather.)

Basic beverages and snacks will be provided.

If you are interested in attending, please let me know by Email (lubedealerdon@gmail.com) of your interest and I will ensure you are on the list to receive an official invite.

Please send subjects you wish to be covered or questions you would like to have answered. This is an Education Night for YOU!

Tentatively scheduled for Thursday Evenings from 7 PM to 8 PM. No sales pitches will be given. Anyone needing to pick up products please wait until the meeting has ended.

(Please contact me for one-on-one meetings/training for you and/or your group).



Dealer Contact

Lincoln - Olson Marketing

Don & Peg Olson

ZO Referral# 4901

402-489-3930

<http://om.shopamsoil.com>

lubedealerdon@gmail.com